



MANUAL INSTRUCTION

Central heating stove – MBS THERMO
PELLET

DEAR CUSTOMER,

We appreciate your trust dedicated to us and your determination to buy our product.

You made a good choice, since this stove has technical characteristics which place it into top class, and you will be assured of it during exploitation.

Please, carefully read this manual before you start to use his stove, since you will find tips and tricks for proper handling.

We believe that you will be one of the millions of satisfied customers of our products.

A.D. „Milan Blagojević“ Smederevo

Contents:

General comments.....	1
Pellet.....	2
Package.....	2
Assembly of the stove.....	3
Operation.....	4
Cleaning and maintenance.....	4
Technical data.....	5
Integral parts of the stove.....	6
Handling.....	7
• 1. Power.....	8
• 2. Settings up of heating intensity (heating power).....	10
• 3. Setting up of desired temperature.....	10
• 4. Achieving of temperature during operation.....	10
• 5. Turning off.....	11
• 5.1. Remote control.....	11
• 6. Setting up of the time and date on the display.....	12
• 7. Programming.....	14
• 7.1. Daily programming.....	14
• 7.2. Weekly programming.....	16
• 7.3. Weekend programming.....	18
• 8. Alarms.....	20
Warranty statement.....	22

GENERAL COMMENTS

- Read and study contents of this instructions and observe the same during assembly and usage of the stove;
- Children and persons with reduced psycho-physical abilities should not handle the stove;
- Do not allow pets in the vicinity of the stove;
- During operation, stove emits heat. Do not make contact with hot parts of stove (glass, smoke exhaust, door) since there is danger of burns. Do not allow children to touch hot part of stove. Do not open firebox door during operation;
- Ash from ashtray should be removed when stove and ash are cold;
- Firebox and internal parts of the stove are to be cleaned when it is disconnected from electric current and cold, as well as ash;
- Use only original spare parts delivered by manufacturer;
- Use pellet as exclusive fuel. Pellets must be of quality high-calory woods, dry, cylindrical, glossy and compact;
- Stove is to be exclusively used for heating;
- During mounting, draft of the chimney must be within allowed limits (2-12Pa);
- Provide continuous intake of clean air in the room in which stove combusts pellet;
- Device is made of material which may be recycled;
- Stove which is not going to be used again should be properly disposed. Dispose it of to the proper place, in accordance with recommendations for removal of used electrical and electronic devices. Cut of power cable prior to disposal. Observe actual environmental laws;
- Do not disconnect stove by pulling out cable from the plug. Observe instructions given in the part "Handling";
- During first use of the stove, combustion products may occur from protective cover and humidification of color from installed parts, thus ventilate the room;
- Stove is leaned on adjustable legs which should be adjusted in order to make stove stable and with no slopes;
- All reclamations, evaluated as defects or weakly functioning, please report to factory or authorized service by phone or in written. At the end of these instructions there are phone numbers of technical services. Any defect of the stove is to remedied exclusively by factory or authorized service; If unauthorized persons perform servicing or any other repairs on the stove as self-initiative, owner of the stove will loose right to service guaranteed by the manufacturers guarantee;
- Stove is equipped with device for igniting the pellets, thus it is not allowed to carry out ignition in any other way then described (see "Handling" - "Operation").

In case of non-observance of instruction manual, manufacturer will not bear any liability for damage on the stove.

PELLET

Description

Pellet is the product obtained by pressing sawdust and cuttings of dry, high-calory wood. During pressing, additional binders are not allowed. As clean product of biomass, pellets are CO₂ neutral, i.e. do not contribute to effect of green house. Wood as basic ingredient of pellet is renewable source of energy and fuel of the future.

Characteristics:

- By combustion of pellet, only 1% of ash occurs;
- Energy value is approx. 5kWh/kg;
- 2kg of pellet is approx. 1l of fuel oil;
- Combustion of pellet emits CO₂ equal to the amount used by the wood during its growth;
- 1m³ of pellet has mass of approx. 640kg.

How to recognize quality pellet:

- Pellet must have cylindrical shape, we recommend pellet 5 to 7mm in diameter of 10 to 25 mm length;
- Cylindrical surface must be glossy;
- Pellet must be without dust and dirt;
- Humidity must be less then 10%;
- Package must be hermetically closed, since pellet absorbs water;
- By sinking into vessel with water, quality pellet will fall to the bottom;
- Avoid pellet of poor quality wood, wooden residues with additions of seedoil rape and binding agents.

PACKAGE

Package of the stove is to be removed during mounting, i.e. prior to operation. All materials may be recycled. Packing material (plastic bags, parts of polystyrene-styropor etc.) should be kept out of reach of children, since it is potential source of danger.

Plastic parts of package are to be disposed of to proper areas, do not burn them. Pay attention to safety since wooden parts of package are joint with nails, thus during disassembly and disposing of wooden bars injuries may happen.

ASSEMBLY OF THE STOVE

During assembly of the stove, observe regulations related to safety and environment. Provide room in which stove will be mounted with sufficient combustion air.

Connect stove to the power 230V, 50Hz. Connection spot must be done pursuant to the requirements of electricity distributor and valid regulations. Power cable must be without damages, may not cross over heat areas of the stove, neither over other devices which may melt or damage the cable.

Prior to mounting of the stove, check if chimney is performed in accordance with regulations, are there any disturbances in the chimney or any cracks. Remove all irregularities prior to operation. Stove may not be installed in direct vicinity of wooden elements, cooling devices or plastic parts of furniture and other inflammable materials since during its operation (at the combustion of fuel) it achieves very high working temperature which is distributed at the exterior of the stove. The least distance between stove and surrounding inflammable elements is, on back side 20 cm, lateral 20 cm, front 80 cm. If surface on which stove will be placed is of inflammable material (wood, warm floor, laminate...) it is necessary to place protection made of metal sheet which covers gabarites of the base: lateral 10 cm, front 30 cm.

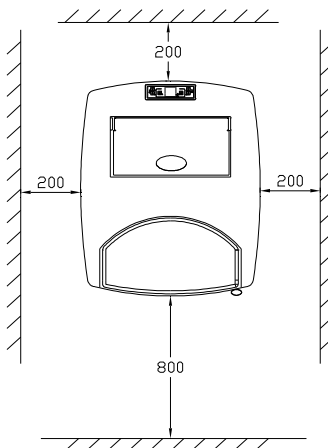

Stove is to be connected with chimney via smoke exhaust pipes via connection at the back of stove, in order to provide adequate sealing and flow of smoke from the stove towards chimney. Flue pipes may not be too deeply installed into the chimney to avoid reduction of area of cross section thus preventing draft in the chimney.

Prior to installation of the stove check draft of chimney since it is one of key factors of proper operation of the stove. Draft depends on accuracy of chimney and meteorological conditions. One of most simple aspects for checking of draft in chimney is using candle flame, as displayed on fig. 1. Put candle flame to connection opening of chimney and if it sways towards opening, draft is satisfactory (fig, 1b).

Weak swaying of flame is indicator of weak draft (fig. 1a).

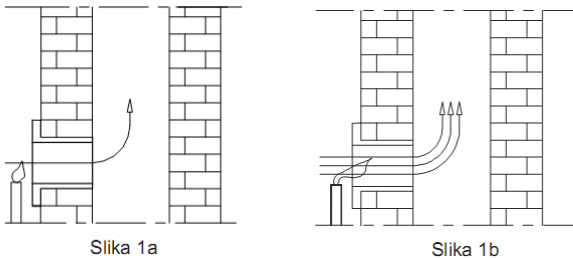

If chimney draft is weak, check accuracy of chimney. Chimney should be located in interior of the building, and if it is in external walls of building, we recommend insulation.

Default of chimney may be:

1. weakly installed windshield,
2. foreign body or bulges inside,
3. cracks of chimney,
4. accumulated tar,
5. weak sealing of connections and cleaning opening,
6. too deep installed smoke exhaust pipe,
7. fireplace without door or some other opening on the chimney
8. weak sealing of connection and cleaning apertures.

Chimney on which stove is connected may not include other devices.

Connection of the stove to the central heating system

Following diagram should be only as sample for connection of oven to the central heating system. Installation should be carried out by expert – electrician. During installation, take care of regulations which are valid for given region or country. Mounting and checking of mounted elements should be carried out by specialized person.

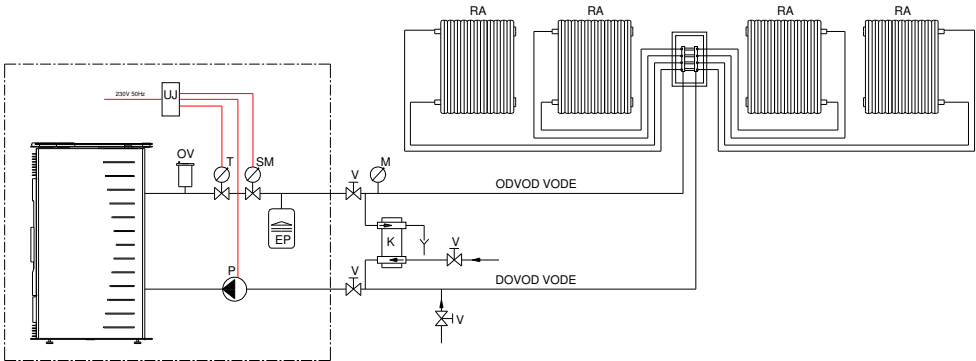

Diagram 1.

UJ – Managing unit

OV – automatic exhaust valve (should be installed one more valve at the highest point of the heating system)

T – Thermometer

SM – Safety manometer

EP – expansion vessel

V – Valve

M – Manometer

RA – Radiator

K – Safety valve “caleffi 544 1/2”

P – Pump

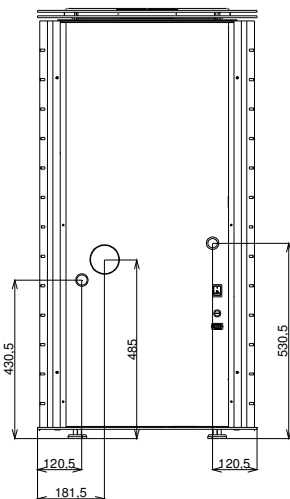

Diagram 2.

OPERATION

- During first operation, there is combustion of protective agents which used to be there during manufacture and storage of stove elements, and evaporation of color by which stove parts are protected against corrosion. Thus, please ventilate the room in terms of removal of undesired scents.
- During first operation, we recommend presence of expert within 30 min, thus he can assure observance of all requirements for proper and safe operation of the stove.
- Check if stove is properly connected to the electric current, with chimney, on safe distance of inflammable materials, supplied with quality pellet and provide stove with supply of fresh air for combustion. On the back side of stove in lower left part, there is switch with marks 0 and 1 (fig. 2. pos. 16). When you confirm observance of all prerequisites for operation of the stove, turn on electric power by turning the switch into position 1, and follow further instructions on their part "Handling".

Cleaning and maintenance:

- During cleaning, turn off the stove from the main power;
- Clean the stove exclusively when cold;
- Glass on the stove is to be cleaned with wet mop. If necessary, use water and soft detergents, but only when glass is cold. Abrasive agents will damage glass so do not use them. Pay attention to, after cleaning of glass surfaces, remove humidity and prior to operation provide it dry;
- Colored and enameled parts are not to be cleaned with abrasive agents since it will remove protective cover. Use solution of water and detergent. Take wet mop or sponge and slightly clean unclean parts, rinse them with water after washing and dry surfaces which are covered with color or enameled electrostatically. Do not allow water to penetrate to electric parts of the stove;
- Regularly, after usage, when stove and ash got cold, clean ash from the firebox. Use vacuum devices for cleaning of firebox;
- Regularly empty ashtray, only when stove is turned off;
- Pay attention that vessel for combustion of pellets is always clean, and openings for draft are always passable.
- Once a month, clean area behind ashtray by removing the closure (fig.2a). Closure is to be removed by unscrewing 4 screws. Use vacuum cleaner to clean chamber. Prior to operation, return closure to its place and secure it. It is also necessary to remove closure of smoke gases (fig. 2b) which is located below majolica (ceramic plate) and which is secured with two locknuts, and use handle to elevate and low lower

Central heating stove - MBS Thermo Pellet

Tubulators several times. Prior to operation, return closures to their places and secure them with screws and locknuts.

Fig. 2a

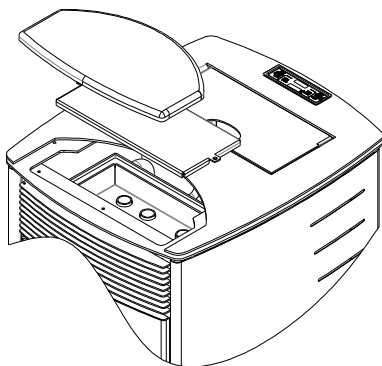
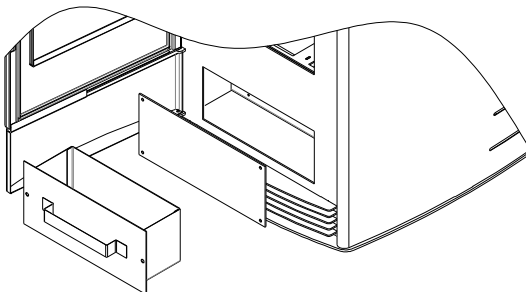
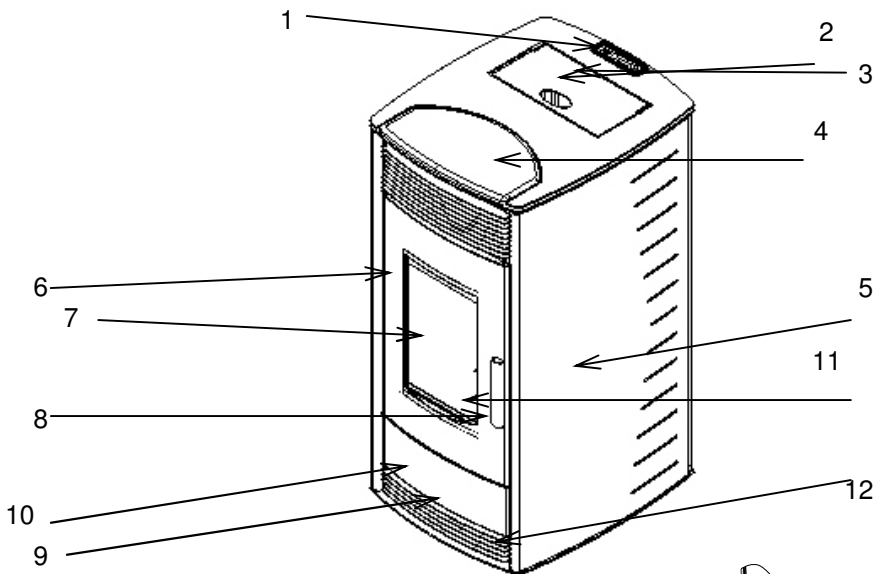

Fig. 2b

TECHNICAL DATA

EN 14785				
Dimensions H x W x D	mm	1168 x 596 x 713		
Chimney connection		back side, Ø80mm		
Height from the floor to the axis of smoke exhaust connection	mm	490		
Voltage (50Hz)	W	500**		
Power of electric part	V	230		
Nominal power (water + room) (12/15/18 kW)	kW	8+4	11+4	14+4
Water connector		1"		
Emission of CO reduced to 13% O ₂	%	0,03		
Temperature of exhaust gases	°C	115		
Weight	kg	165		
Efficiency	%	89		
Fuel		pellet		
Max. consumption (12/15/18 kW)	kg/h	2,6	3,4	4,1
Min. consumption	kg/h	1,5		
Draft	Pa	2-12		

** Comment: Motor of ventilator of exhaust gases has power 54W, motor of pellet sorter has power 45W, as well as igniter (lighter) 350W. Igniter (lighter) is turned on only upon firing of pellets. During operation of the stove, certain motors work in the mode which is programmed by default. There is also circulation pump of 60 W power which is turned on from time to time.



Integral parts:

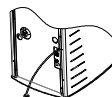

- 1 - display
- 2 - pellet container door
- 3 - pellet container
- 4 - ceramic plate
- 5 - lateral side
- 6 - firebox door
- 7 - firebox door glass
- 8 - firebox door handle
- 9 - ashtray door
- 10 - ashtray
- 11 - firebox
- 12 - front side
- 13 - intake and discharge of water
- 14 - smoke exhaust
- 15 - thermal switch
- 16 - switch for turn on/off
- 17 - connecting cable for main power
- 18 - probe for measuring ambient temperature

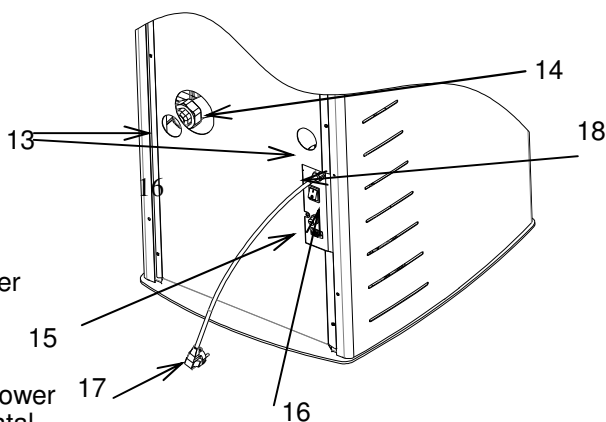

HANDLING

Control panel enables communication with programmer using buttons. Display and indicators (on LCD display) inform operator of operation of stove.

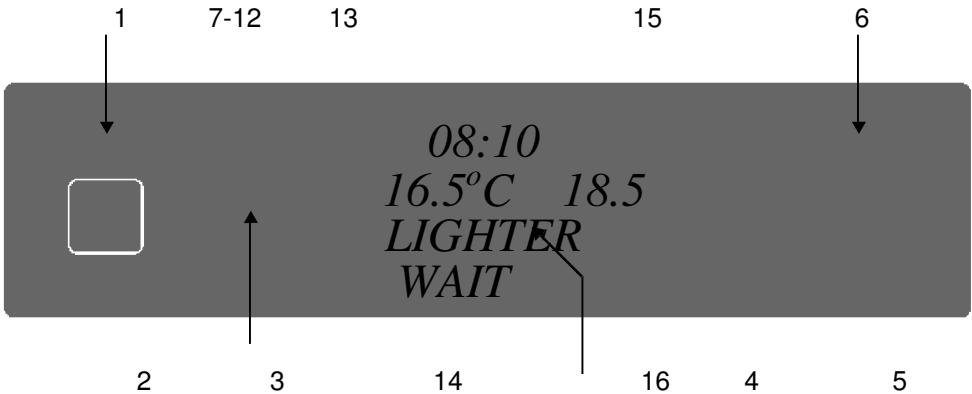







Overview:

Buttons:

- 1 - Increase of temperature and program functions of day, time
- 2 - reduction of temperature and programske function of day, time
- 3 - change of program SET
- 4 - ON/OFF, exit
- 5 - reduction of heat intensity
- 6 - increase of heat intensity

Display on central part of control panel:

- 7 - clock - programming active 
- 8 - heater - active – 
- 9 - diagram display of pellet – active fuel intake – 
- 10 - turbine - ventilator of exhaust gased active - 
- 11 - pump – active circulation pump- 
- 12 – alarm indicator - 
- 13 – clock
- 14 - indicator of room temperature

15 - water temperature indicator

16 – Operating information

1. Operation

When stove is connected to electric power, turn current switch located on back side of stove to position I. Then, on display, following messages will occur: time, room temperature, water temperature and OFF- stove not in operation (fig. 4).



Fig. 4.

Press Button 4 (turning on) for few seconds. Alteration of message on display from OFF to START indicates beginning of operation (fig. 5), heater is active (fig. 6) and followed with message LIGHTER WAIT. After that, messages LOAD PELLET and FIRE WAIT occur alternately, which indicates filling of stove with pellets and intake to firebox following by ignition of fire in the firebox (fig. 7 and 8).



Fig. 5.



Fig. 6.

Fig. 7.



Fig. 8.

When flame occurs in the firebox, lighter (igniter) is switched off and display indicates message FLAME LIGHT (fig. 9).

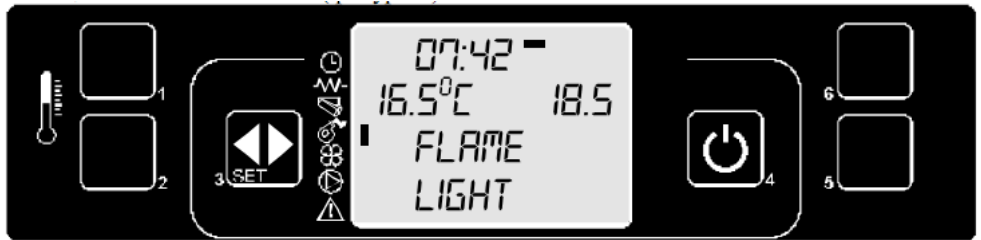

Fig. 9.

After obtaining stable flame, display indicates WORK (fig. 10). When stove enters stable process, every 20 min, in sequence of 40 sec there is stoppage of intake of pellets and starts cleaning of firebox cup against unburned pellets, followed by message CLEANING FIRE-POT.



Fig. 10.

2. Setting up of heating intensity (heating power)

Button 6 selects desired intensity of heating, which may be read on display where message SET OUTPUT occurs and numerical value 01 to 05 (fig. 11). The highest intensity of heating is 05.

Fig. 11.

3. Setting up of desired temperature

Desired room temperature in which stove is located may be set by pressing button 2 after which display will indicate desired temperature as shown on fig. 12.



Fig. 12.

4. Setting up of water temperature in the boiler

Desired water temperature may be set during operation, by pressing button 1, after which display will show SET TEMP WATER, as on fig. 13. Temperature of water may be set to max. 80°C.



Fig. 13.

5. Achieving desired temperature during operation

After obtaining given ambiental temperature, of water temperature, stove proceeds to economic mode whereat fuel is saved, and display indicates WORK MODULAT as on fig. 14.

Fig. 14.

5. Turning off

Stove is to be turned off by pressing button 4 in sequence of 2 to 3 seconds. Passer ceases with work, ventilator of smoke gases is still turned on for about 10 min until temperature of exhaust gases is reduced below given value, while turning off the flame and reduce temperature of stove. Also, ventilator for fresh air additionally discharges air until stove is cold enough. This activity is followed with message CLEANING FINAL on display, whereat indicators are turned on that both ventilators are operational, as on fig. 14a. After getting cold, both ventilators cease work and display shows OFF and stove is turned off as on fig. 15.



Fig. 14a.



Fig. 15.

New start of the stove is possible only after decrease of temperature below prescribed.

5.1 Remote control

Temperature and capacity of heating may be set by remote control. It has symbol of temperature (thermometer) and signs + and - (left side of remote control), as well as symbol of fire with signs + and - (right side of controller). Appropriate sign + serves for increase, and – for decrease of the value of temperature and capacity. Use only battery P23GA (12V).

6. Setting up time and date on display

Stove which uses pellet has possibility of switching on and off during the day via

programs. In order to program the stove, it is necessary to set up time and date on display of control panel. In order to do it, it is necessary to access menu for setup of time and date. Press button SET and via button 5 reach the menu 02 as shown on fig. 16.



Fig. 16.

Press SET and use buttons 1 or 2 to set date in the week (MONDAY, TUESDAY...) fig. 17. Press SET and use 1 or 2 to set time, fig. 18.



Fig. 17.



Fig. 18.

Press SET and use 1 or 2 to set minutes, fig. 19.
 Press SET and use 1 or 2 to set day, fig. 20
 Press SET and use 1 or 2 to set month, fig. 21.
 Press SET and use 1 or 2 to set year, fig. 22.
 When done, return to main menu by pressing 4.



Fig. 19.



Fig. 20.



Fig. 21.



Fig. 22.

7. Programming of the stove operation

There are 3 sorts of programming:

- Daily;
- weekly;
- weekend.

In the following text you will find each single programming.

7.1. Daily programming

Stove can be switched on and off two times via programs, with reference that it is necessary to take enough time between off and new on to get stove cold. Above all, it is necessary to set time and date (as described in chapter 6). These two actions depend on later functions of the stove turning on and off, thus set correct time.

Press SET and use button 5 to enter the menu 03 as described on fig. 23.



Fig. 23.

Press SET, as on fig. 24.



Fig. 24

Press SET, as on fig. 25. By pressing 1, chronometer is enabled (on) as on fig. 26.



Fig. 25.



Fig. 26.

Press button 4 then 5 and display will look like described on fig. 27.



Fig. 27.

Press 2 times button SET and display will look like described on fig. 28. Use 1 or 2 to set time of first turning on of the stove during the day. By pressing SET display will look like described on fig. 29 and use 1 or 2 to set time of first turning off.



Fig. 28.



Fig. 29.



Fig. 30.

By pressing SET, you will go to setup of other program. Use button 1 to set time of turning on (fig. 30). Press SET and set time of turning off (fig. 31). When setting up is finished, use 4 to return to main menu and display will show indicator that programming is finished.



Fig. 31.

7.02 Weekly programming

Week program has 4 programs (4 times of turning off and on). For each weekday, individually, you may combine these 4 programs i.e. whether one of them will be active or not (OFF or ON). Pay attention to carefully set programs in order to avoid overlapping of times of turning on and off. Programming procedure is as follows:

First 4 steps upon programming are same as at setting up of daily program (fig. 23-26). Press 4 and then two times press button 5 and display will look like described on fig. 32.



Fig. 32.

Press SET then 1 and activate week program (ON) and display will look like described on fig. 33.



Fig. 33.

Central heating stove - MBS Thermo Pellet

Press SET and use 1 to set time of starting of the stove in the first program, and display will look like described on fig. 34, repeat same procedure and set time of turning off in first program, fig. 35.



Fig. 34.

Now press SET and use button 1 to activate (ON) or deactivate (OFF) program 1 for appropriate day in the week starting from Monday to Sunday and display will look like described on fig. 36 a 37. Passing from day to day is via button SET.



Fig.35



Fig. 36.



Fig. 37.



Press SET to transfer to setup of other program and its activation for each weekday individually (as for program 1). Do the same procedure for remaining two programs (program 3 and 4). Indicator that programming is active will be indicated on display.

Comment: Deactivate daily program if you want to use week program!

7.03 Weekend program

Weekend program enables programming, turning off and on of the stove, (two times a day) during weekend (Sat and Sun). Activate Weekend program only if daily and weekly programming are deactivated.

First 4 steps are same as at daily program (fig. 23-26). Press 4 then three times button 5 and display will indicate as on fig.38.

Press SET and activate weekend program as described on fig. 39.



Fig.38



Fig. 39.



Fig. 40.

Pressing SET and then 1 we set time of first turning on of the stove as described on fig. 40. By repeated pressing of SET and 1, we set time of turning off and display will indicate as on fig. 41. Same procedure is for programming of another weekend program, fig. 42.



Fig. 41



Fig. 42.

After these settings, return to main menu by pressing 4.

8. Alarms

Irregularities in operation are followed with audible alarm and messages on display related to irregularity. Irregularity during operation may occur due to higher temperature of exhaust gases, improper operation due to temperature of the probe aspirator, when there is obstacles in smoke exhaust, in case if pellet is not fired during the phase of firing, in case of lack of pellet, breakage of electricity, and turning off of stove.

Central heating stove - MBS Thermo Pellet

During first turning on of the stove, switch O/I, on back side, or during circuit breakage, alarm may start as described on fig. 44.

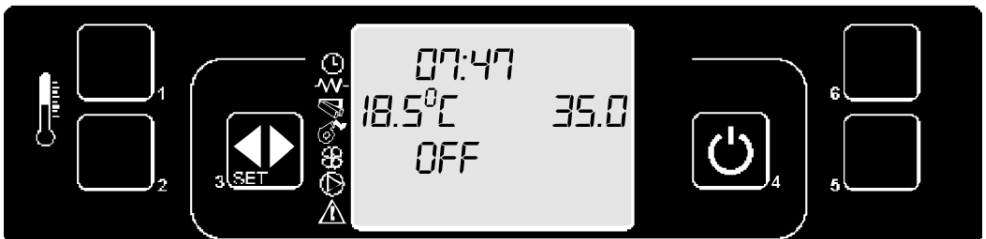

Fig. 44.



Fig. 45.

It is necessary to cancel alarm by pressing button 4 for several seconds, then display will look like on fig. 45. Then you will activate both ventilators and cleaning of the stove is activated for 10 min. When finished, display will show as on fig. 46 and stove is ready for new start.



Central heating stove - MBS Thermo Pellet

In case if pellet is not fired on the very start, message ALARM NO FIRE will occur. This is most frequent occurrence at THE FIRST start of the stove when passer of pellets is empty. Reset alarm by pressing and keeping 4 (all alarms are cancelled by button 4) and stove is started again. Missing firing may occur in case if pellet is of weak quality or wet. Missing firing may occur in case if foreign objects (plastic, pieces of wood, dirt...) disabled passage of pellet from reservoir to the passer. If all previously mentioned is ok, defect is in igniter, so contact service.

Alarm of probe which measures temperature of exhaust gases. Message ALARM SOND occurs in case of defect of probe or if not connected. During activation of alarm, stove starts turning off procedure. In such case, contact service.

If temperature of exhaust gases increases above prescribed temperature (280 °C), message ALARM HOT TEMP will occur. In this case also, stove will turn off. If after attempt of reconstitution of normal operating mode we have same alarm, contact service.

if there is obstacle in smoke exhaust, display wil show ALARM DEP. Check whether physical breakage is in the chimney.

If probe on passer of pellets registers higher temperature then allowed, ALARM SIC is displayed and work of passer of pellets is stopped (spiral) and stove is turned off. In this case, after turning off, on thermal switch which is on back side above switch (fig. 3 pos. 15), unscrew closure of thermal switch and press cylindrical button, and thermal switch returns to working order. Try again to start the stove when allowed by conditions.

If there is defect on ventilator of exhaust gases, ALARM FAN occurs and automatically turns off the stove. In this case, contact service.

If breakage of electricity, ALARM COOL FIRE occurs. After reconstitution of normal supply from main power, turn off the stove and restart.

COMMENT:

CONTROL OF THE QUALITY OF EACH STOVE REQUIRES TURNING ON AND TESTING THROUGH ALL OPERATING MODES. THUS IT IS POSSIBLE IN STORAGE OF PELLETS AND PASSER OF PELLETS TO FIND SOME REMAINING PELLETT.

WARRANTY

MBS declares that central heating stove **MBS THERMO PELLET** will work well if customer observes given instructions.

We will provide spare parts and carry out service of the stove if obstruction during operation occur, and if occurred within warranty period and will remove all problems within 45 days from the date of report. If within indicated period we do not perform repair, you have right to replace the stove by new one.

Warranty is valid from the day of purchase which is evidenced by filled warranty card.

Warranty for this product is 24 months.

Warranty does not cover damages incurred by activity of atmospheric, mechanical, electro-chemical processes, non-observance of instructions, weak storage conditions and inadequate transport. Also, if damages incurred by force majeure (thunder, floods, fire...), electric shock or inadequate working conditions, warranty is invalid.

Parts which are subject to tear and wear during work are not part of warranty, like seals and glass braids.

Protective foil of color and enameled parts, change their color during operation, which is natural feature of applied materials, so they are not subject to warranty.

Please report any defect by informing MBS service by phone or in written form (contacts are given on the last page of manual instruction). Warranty stops due to non-observance of given instructions, negligent handling, amateur repairs or installation of parts which are not original.

During report, please use data from warranty card which must be filled in correctly.

DIAGRAM OF ENERGY OF STOVE – MBS THERMO PELLET

